

Engineering Discoveries: Inclined Planes

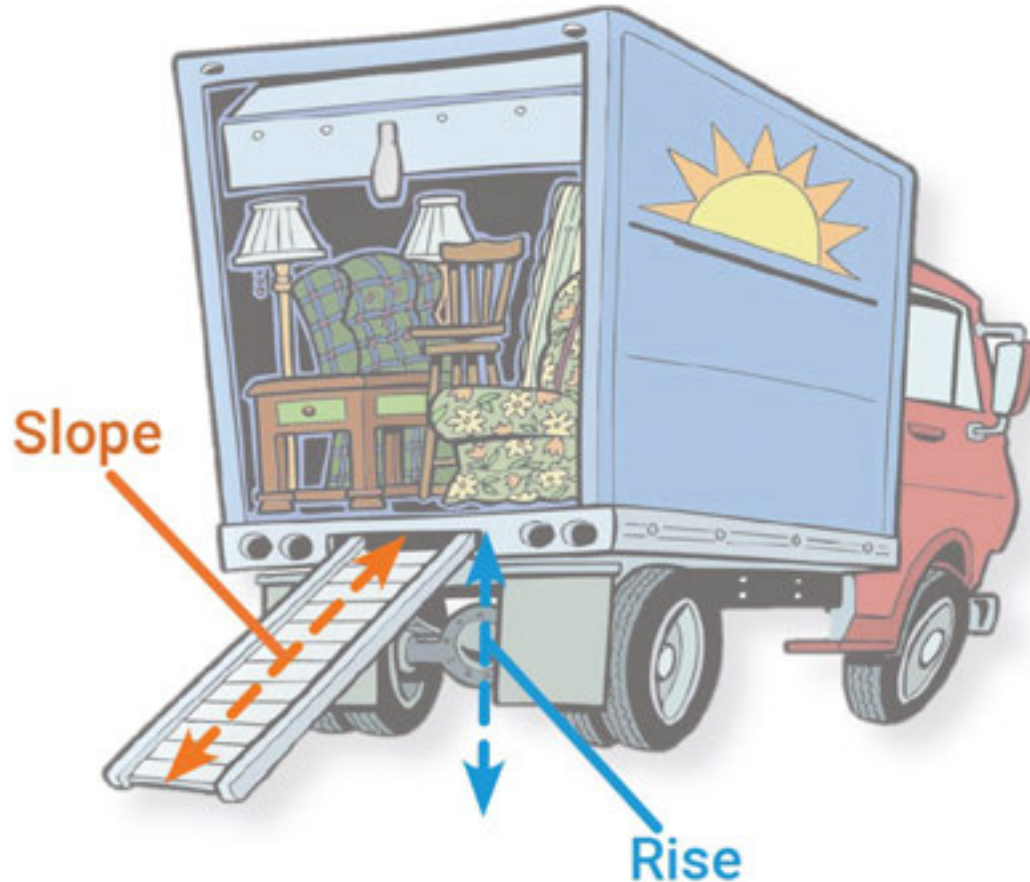

The Inclined Plane

An inclined plane is a flat supporting surface tilted at an angle, with one end higher than the other. There are two elements in an inclined plane: the **slope** and the **rise**. In the example to the right, the slope (incline) is represented by the ramp. It is used to load and unload the furniture in the truck. The rise is the amount of increase from the horizontal surface (the ground in this case) to the top of the slope.



Purpose

An inclined plane is used to make work easier by **creating mechanical advantage**.

Creating Mechanical Advantage

The inclined plane makes work easier by reducing the amount of effort that must be applied to raise or lower a load. This is done by increasing the distance along the length of the slope that the load will travel.

In Example 1, the length of the **slope** (120 cm) is two times the distance as the **rise** (60 cm).

In Example 2, the length of the **slope** (180 cm) has been extended to three times the distance as the **rise** (60 cm). In this example, the load will travel a further distance than Example 1, but the amount of effort needed to raise or lower the load will be reduced.

Example 1 - Inclined Plane

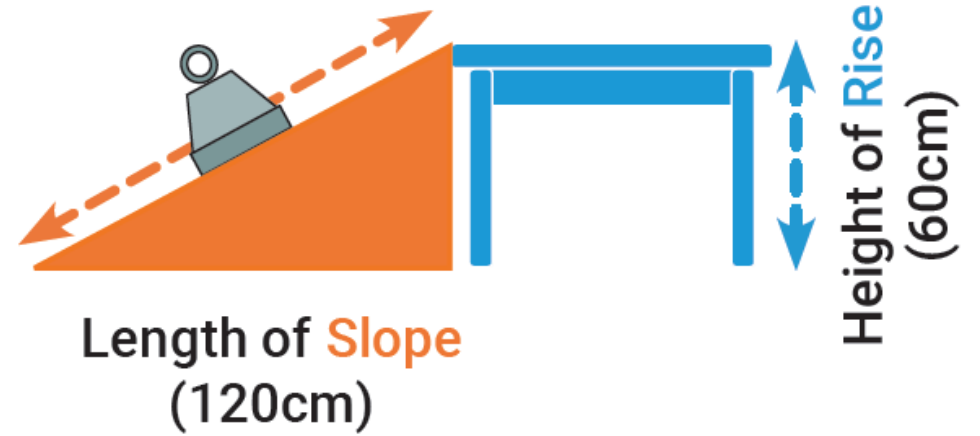

Example 2 - Inclined Plane

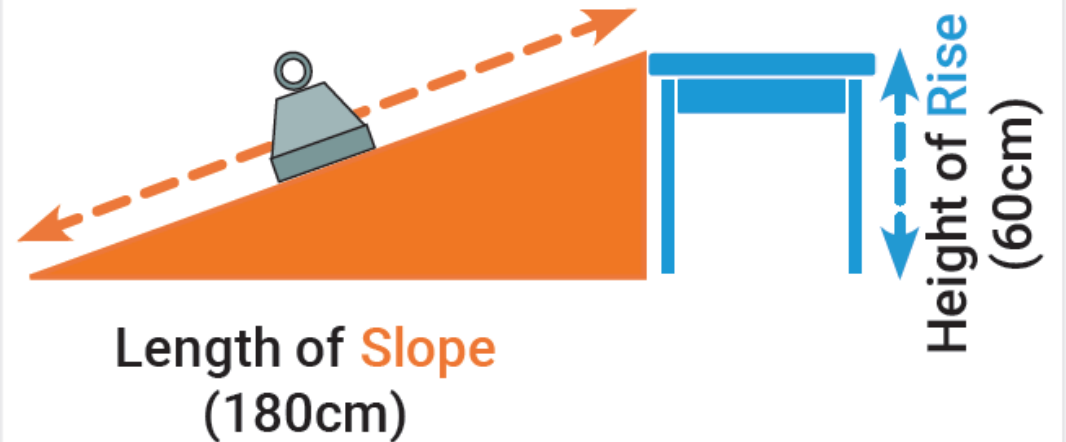

Slides



Skate Ramp



Wheelchair Ramp



Entry Ramp



Ski Slope



Building Basics

Building Basics with Rokenbok

The following tips will be helpful when using the Rokenbok Student Design and Engineering System.

Connecting/Separating ROK Blocks:

ROK Blocks use a friction-fit, pyramid and opening system to connect. Simply press pyramids into openings to connect.

To separate blocks, pull apart.



Connecting/Separating Rokenbok Components

Smaller Rokenbok components use a tab and opening system to connect. Angle one tab into the opening, and then snap into place.

To separate, insert key into the engineered slot and twist.

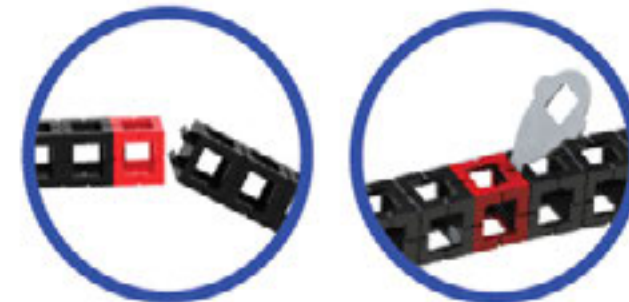

Snapping Across Openings

The tabs on Rokenbok components can also be snapped across openings to provide structural support to a design. This will also allow certain designs to function correctly.



Pyramids or connectors

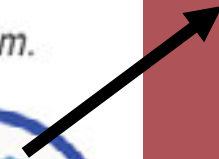

Attaching String:

In some instances, string may be needed in a design. Lay string across opening. Snap any Rokenbok component with tabs or pyramids into opening. Make sure tabs run perpendicular to string for a tight hold.

Measuring:

The outside dimensions of each Rokenbok connector block is 2cm^3 . This means the length, depth, and height are all the same.

To determine the size of a Rokenbok build in cm, simply count the number of openings and multiply by two. Repeat this process for length, depth and height.

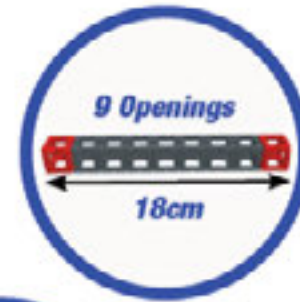
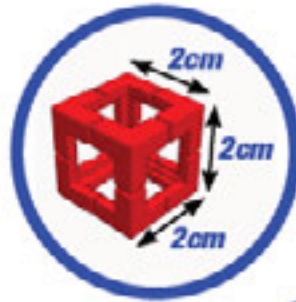
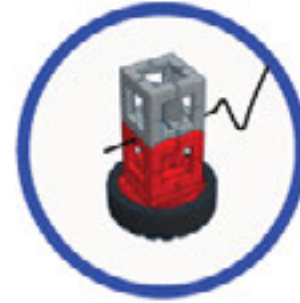
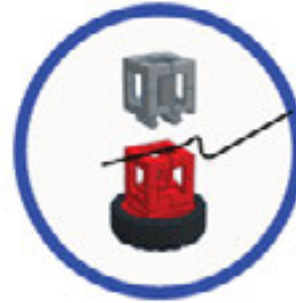

1

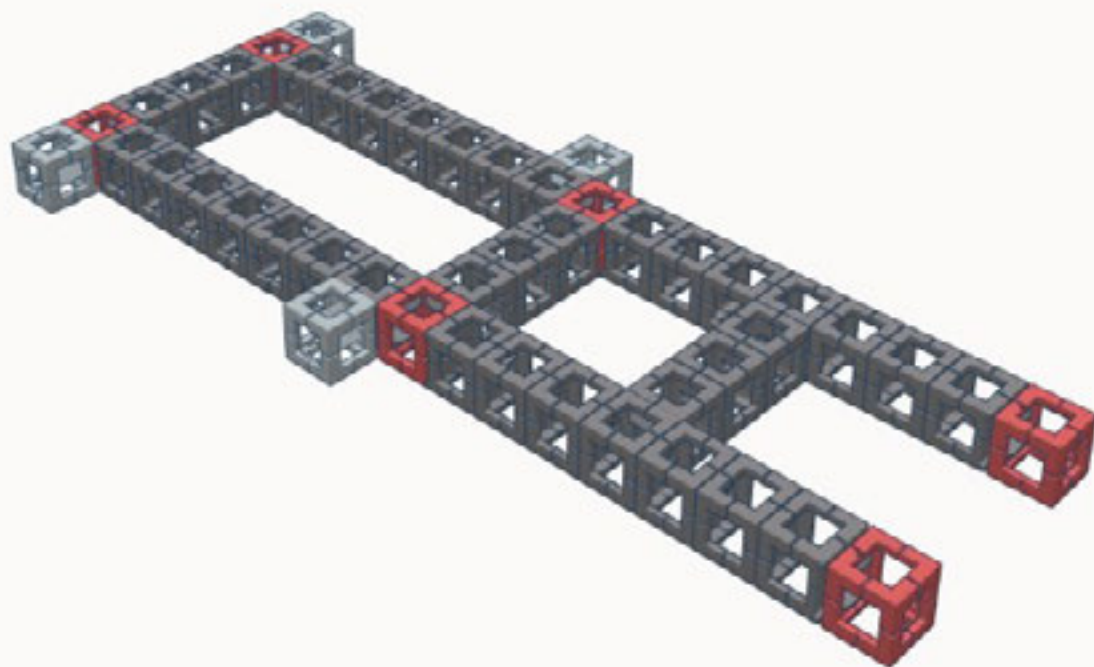

6x
Block



4x
Beam



3x
Half Beam



4x
Single Snap Block



2

Base Structure

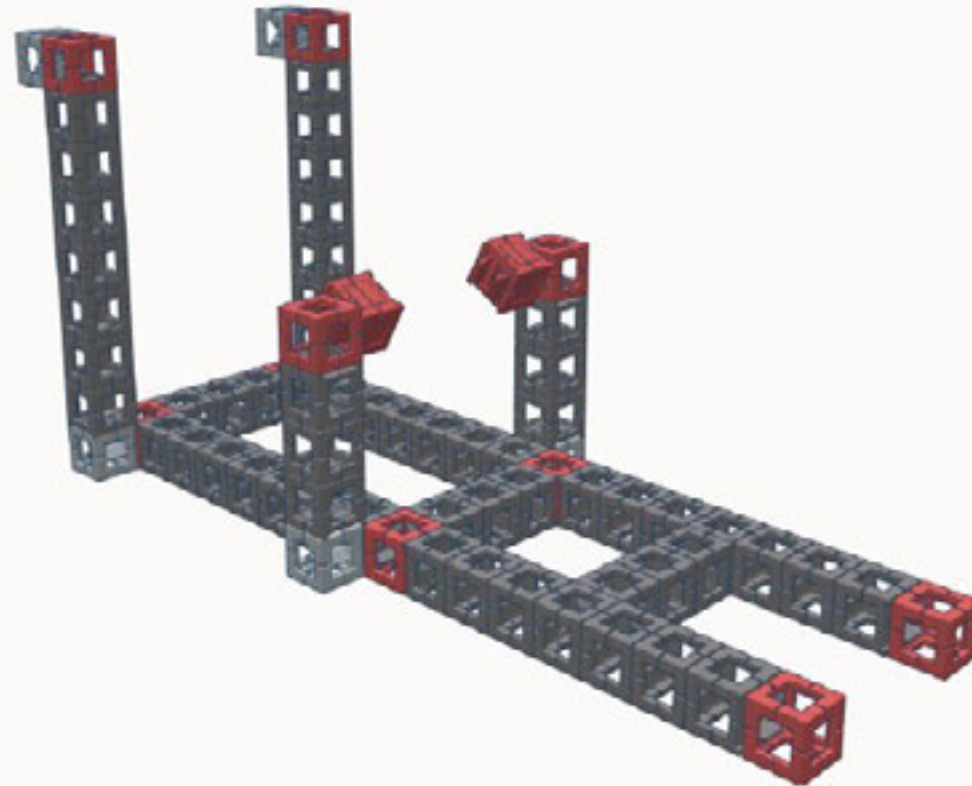

4x
Block



2x
Beam



2x
Half Beam



2x
Single Snap Block



2x
Axle Block



3

Inclined Plane

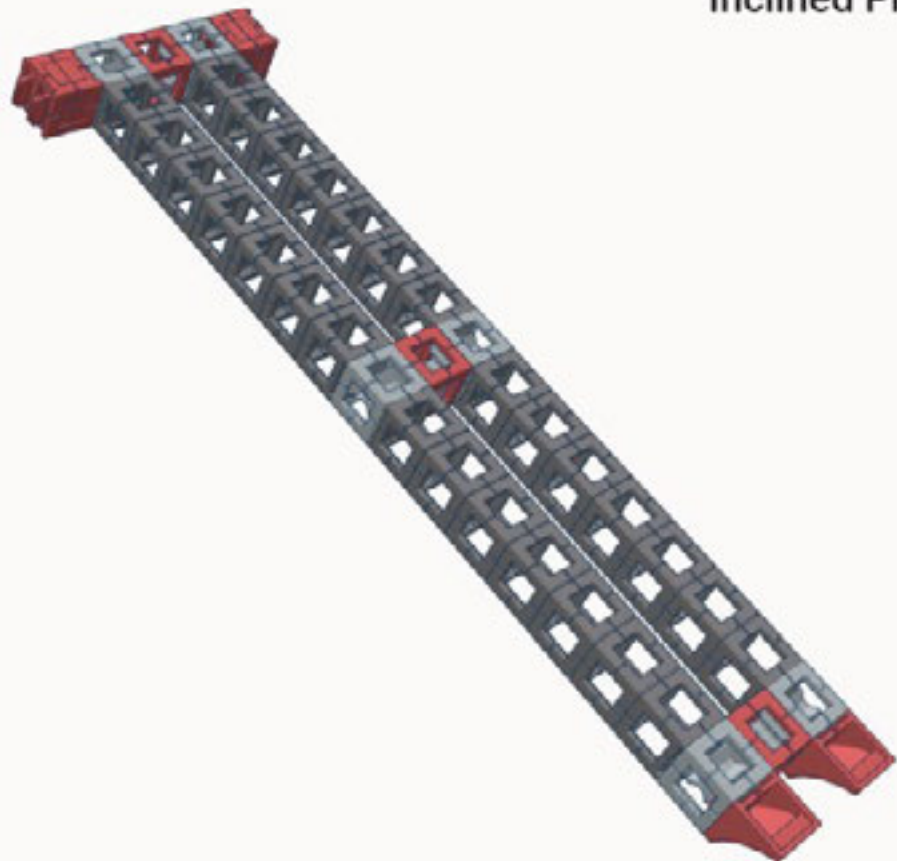

3x
Block



4x
Beam



6x
Single Snap Block



2x
Axle Block



2x
Corbel



4

Attach Inclined Plane
to Base Structure

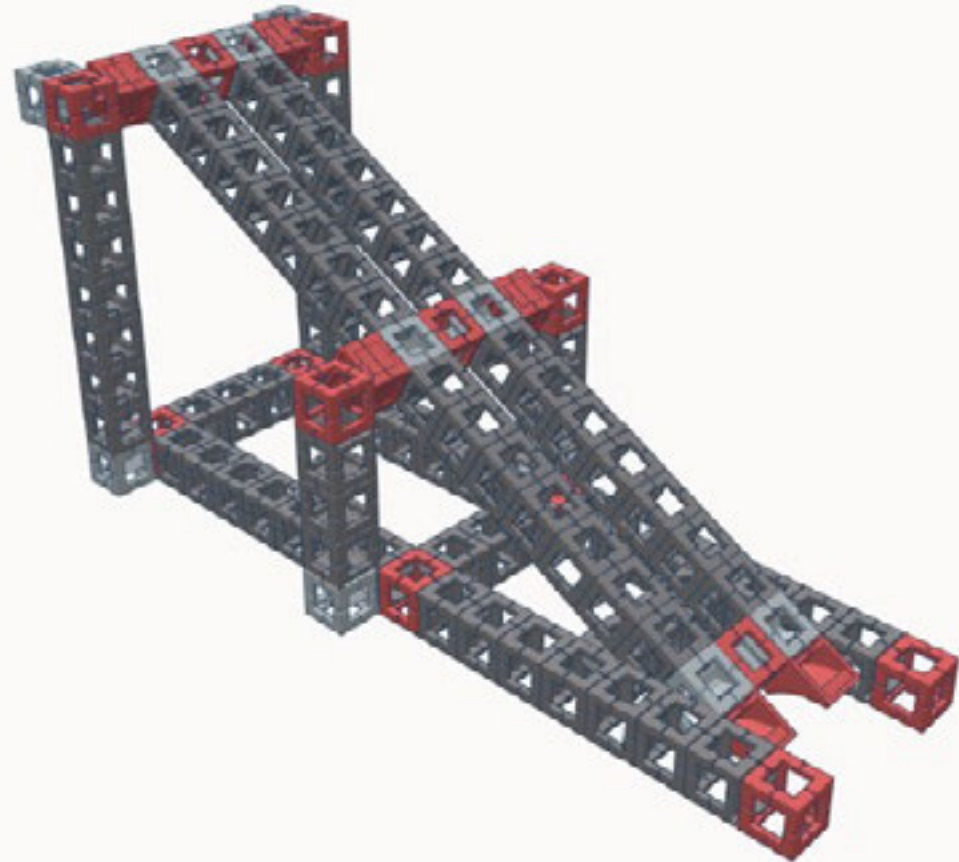

5

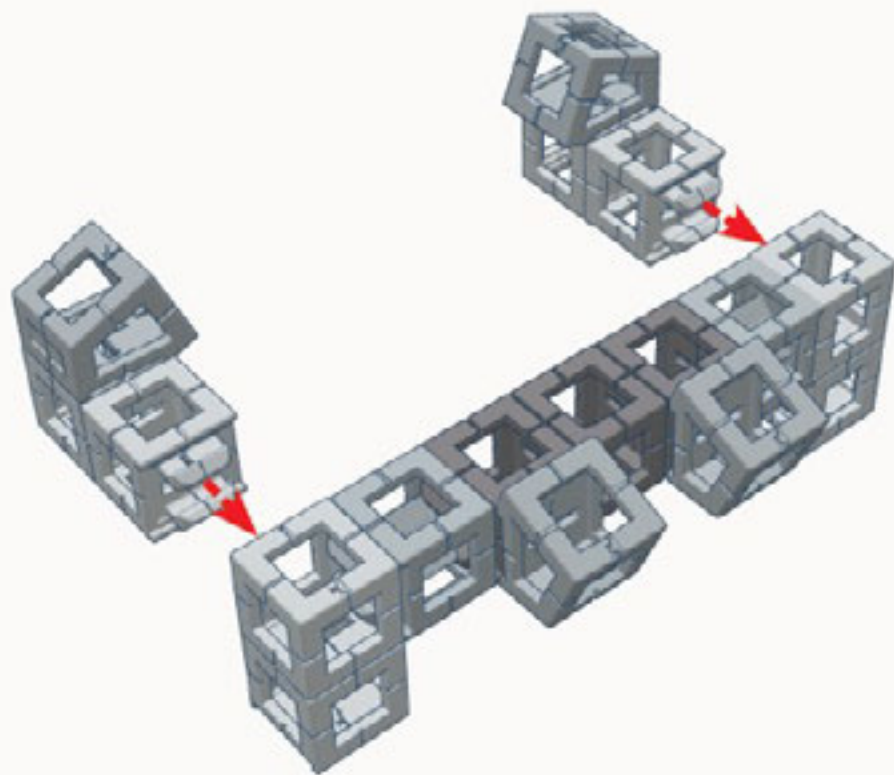

1x
Half Beam



4x
Riser



4x
60° Block



2x
Single Snap Block



6

Pulley Bracket

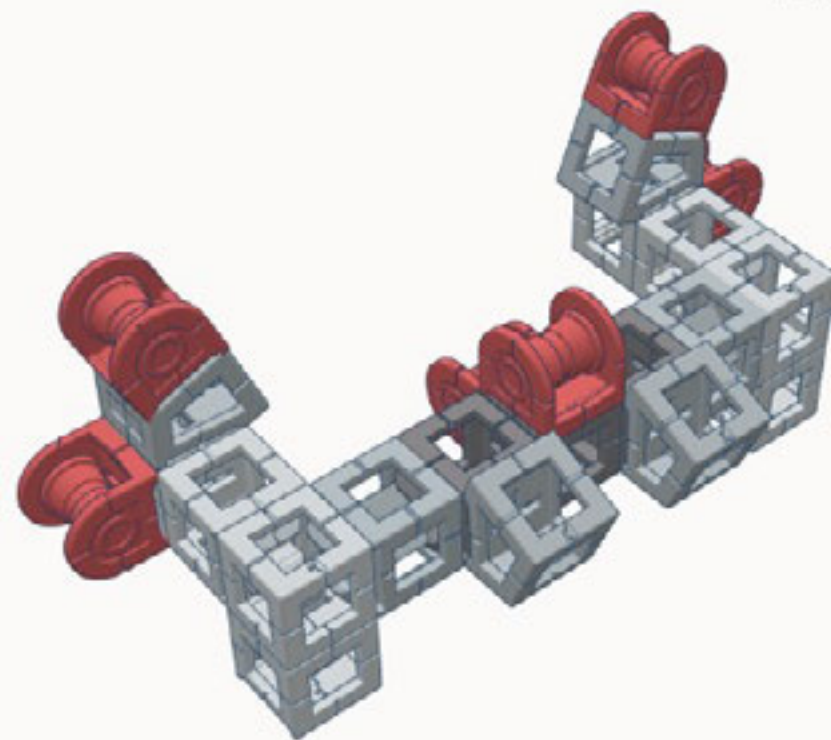

6x
Pulley



7

Guide Rail

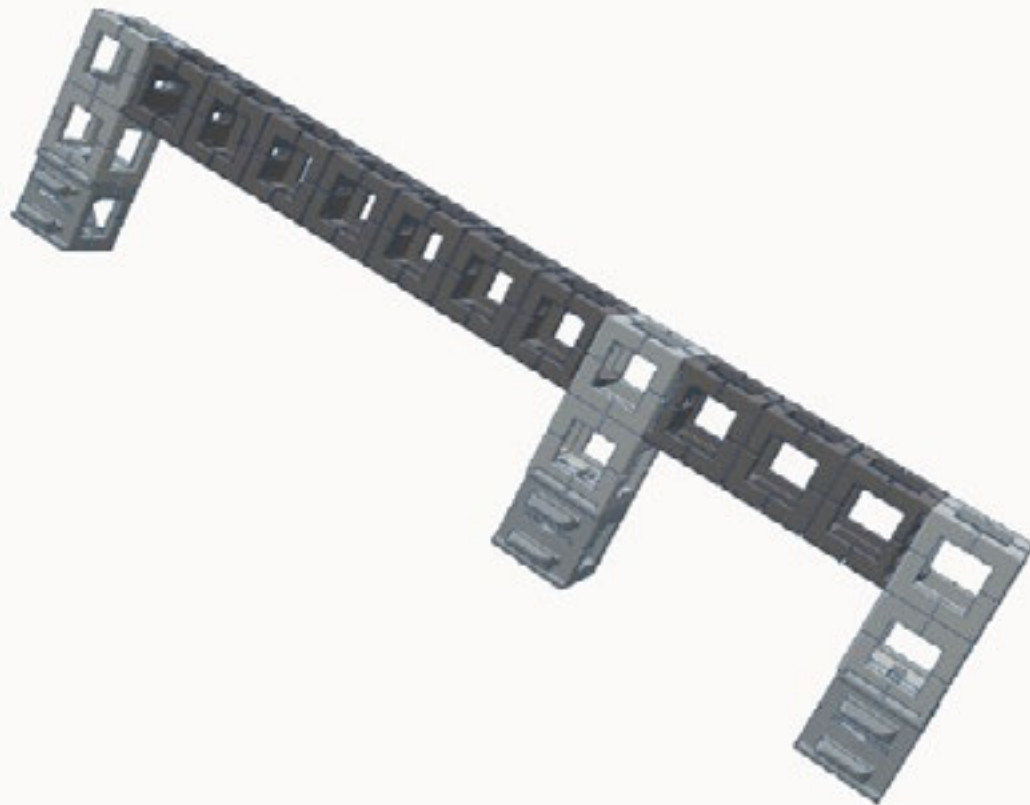

1x
Half Beam



3x
Riser



1x
Beam



3x
Single Snap Block



8

Attach Pulley Bracket and Guide Rail to Inclined Plane

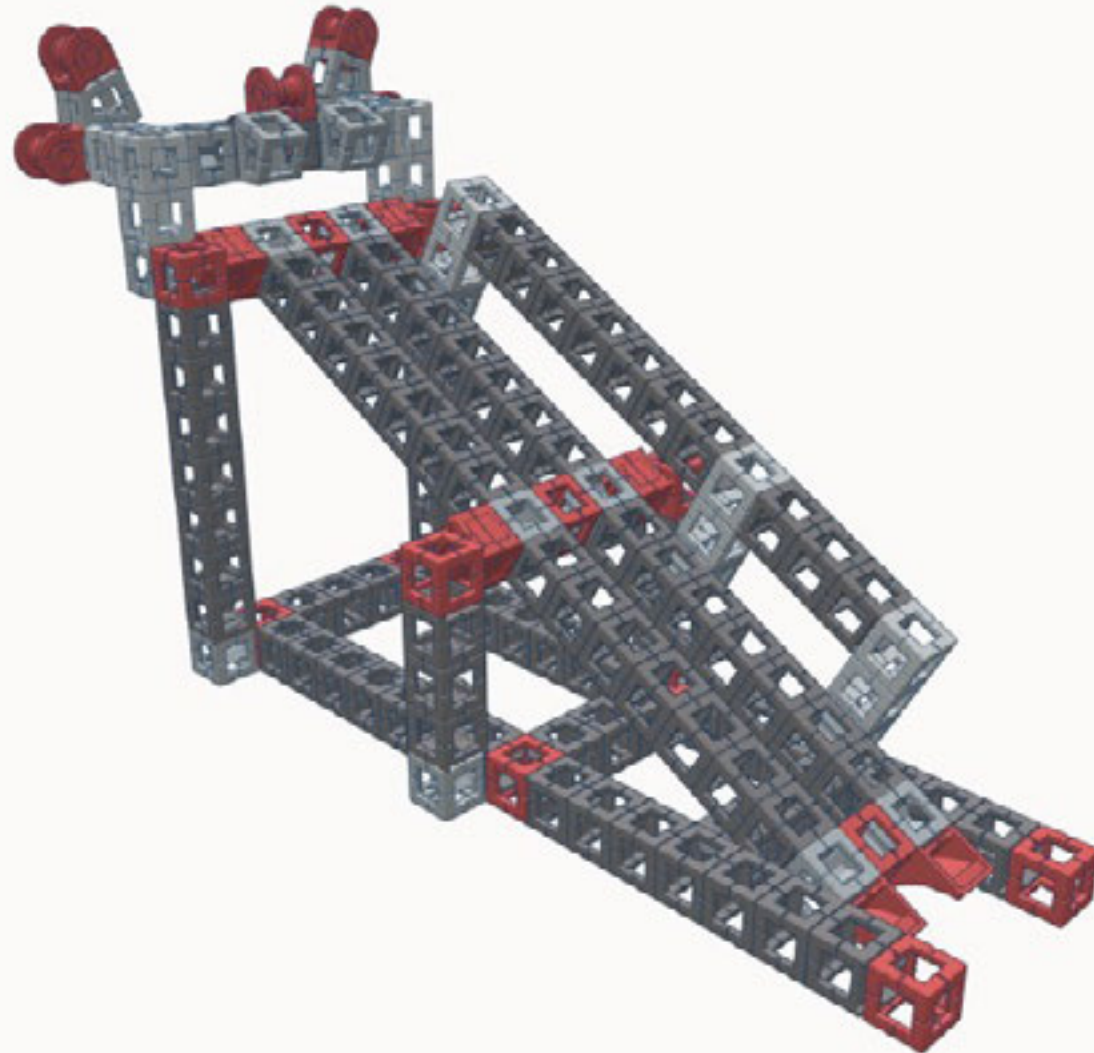

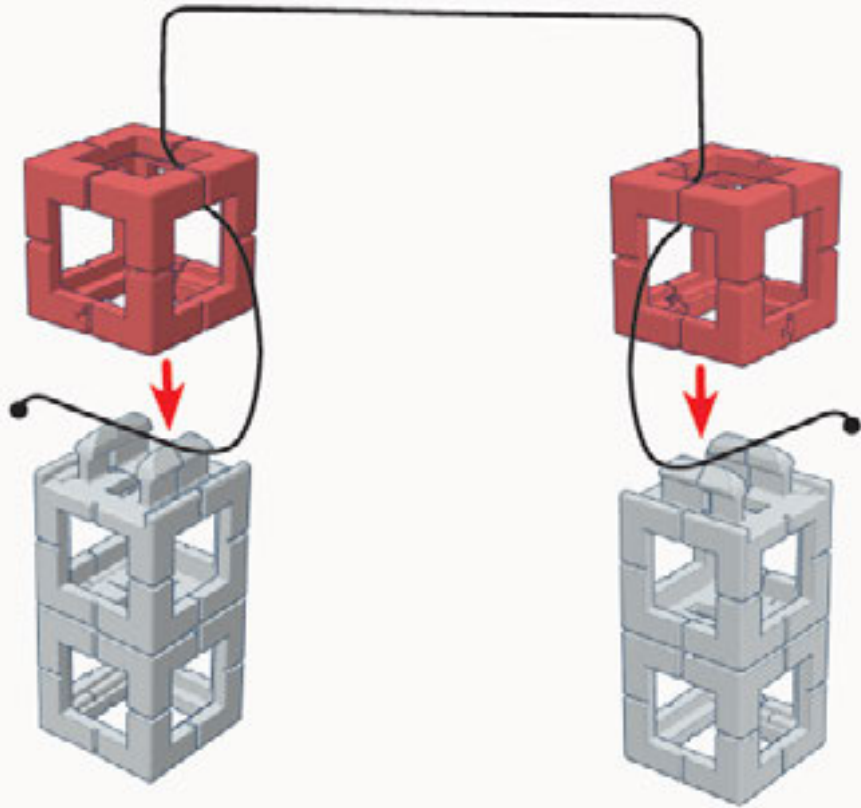

Cut off a piece of string that is 54 cm long. Tie a knot at each end of the string. Feed the string through connector blocks as shown. Secure the string by snapping connector blocks into tabs.

2x
Block



2x
Riser



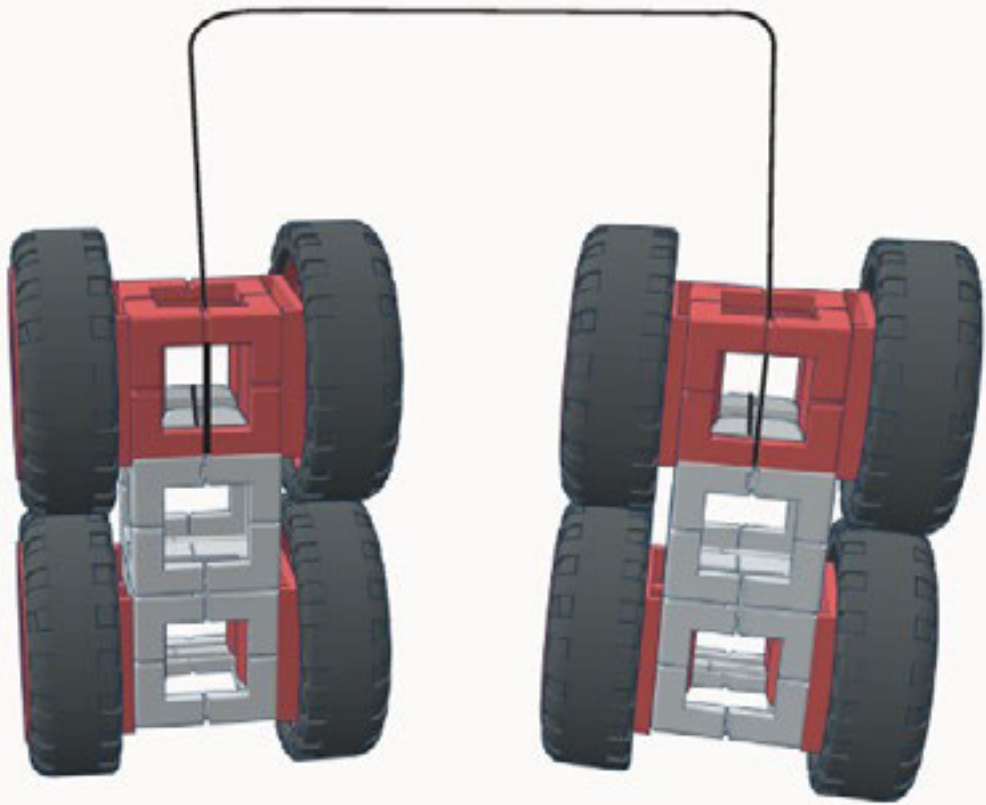

Snap eight wheels into place as shown to finish weights.

8x
Snap-In Wheel



Testing Fixed Pulleys

Turn the inclined plane system so that the weights can be tested on the fixed pulley system. Place the weights over the fixed pulleys. Test and observe how the weights balance each other equally. Pull down on weight 1 and observe how weight 2 moves an equal distance in the opposite direction.

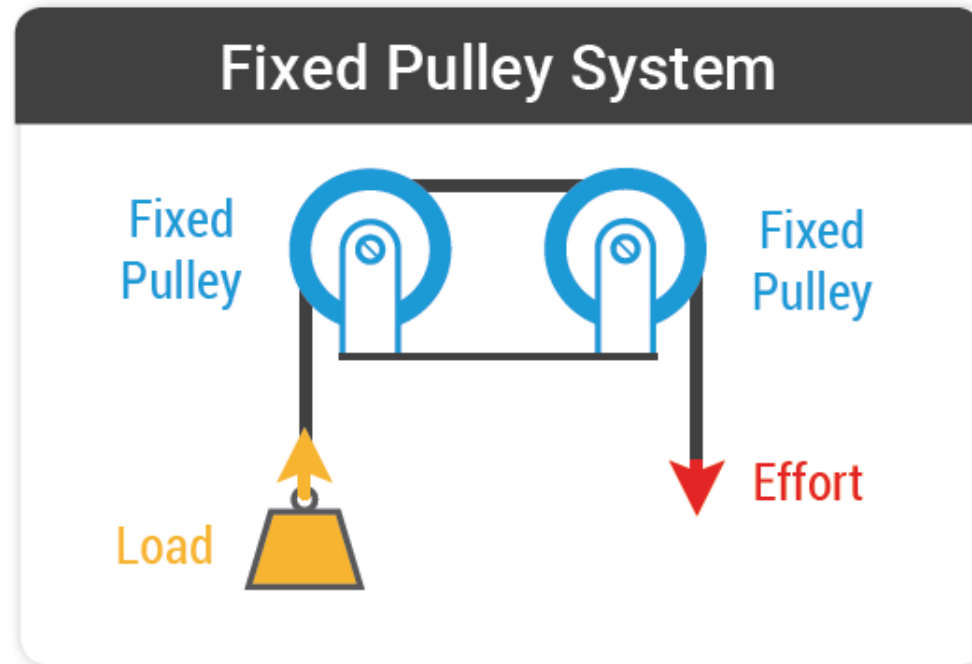

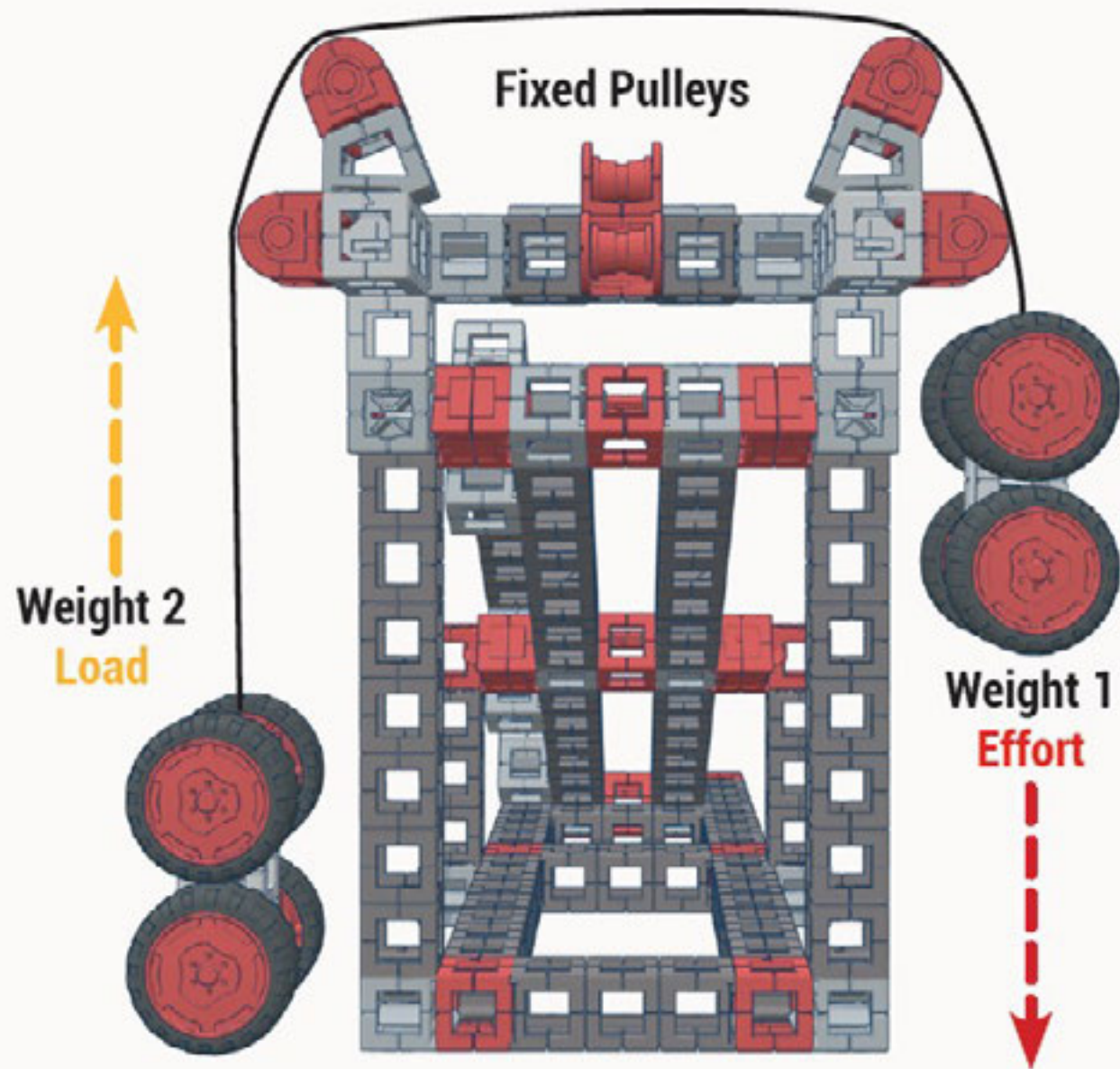

Testing Inclined Plane

A. Move the inclined plane to the edge of a table or desk. The fixed pulleys should be hanging over the edge of the desk or table as shown in Figure A.

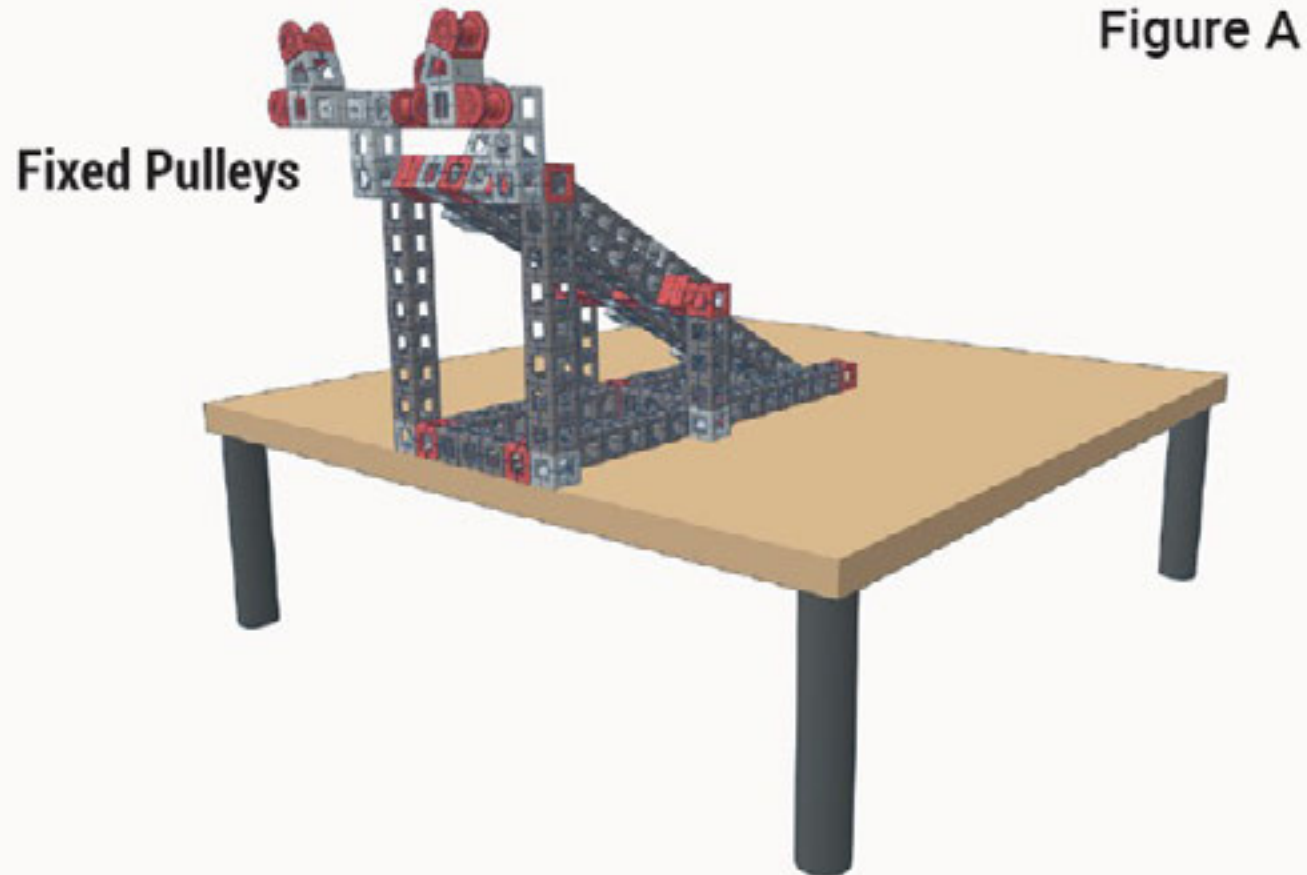

B. Place the weights over the inclined plane as shown in Figure B. Pull Weight 2 down to the bottom of the inclined plane. Release Weight 2 and observe what happens.

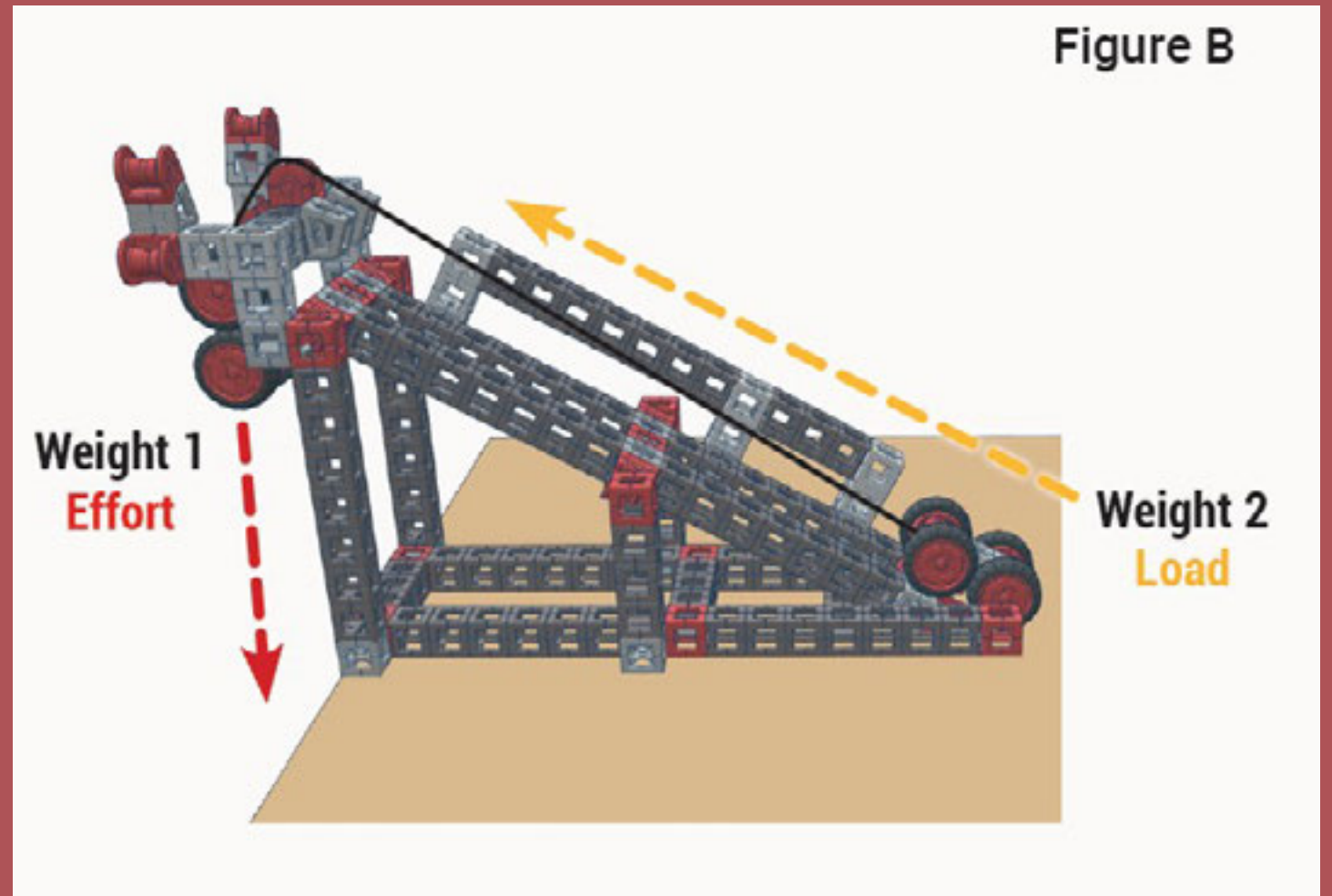
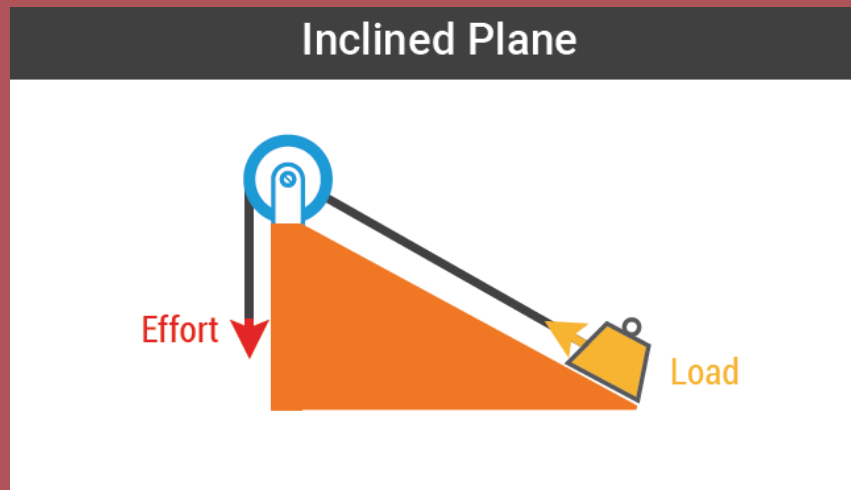

Understanding Mechanical Advantage

The main purpose of a simple machine is to make work easier. This is done by either redirecting motion or creating mechanical advantage. **Mechanical Advantage** exists when the output force of a machine is greater than the input force that was applied to it. To accomplish this, the machine must trade increased time or distance for reduced effort.

Slope and Rise

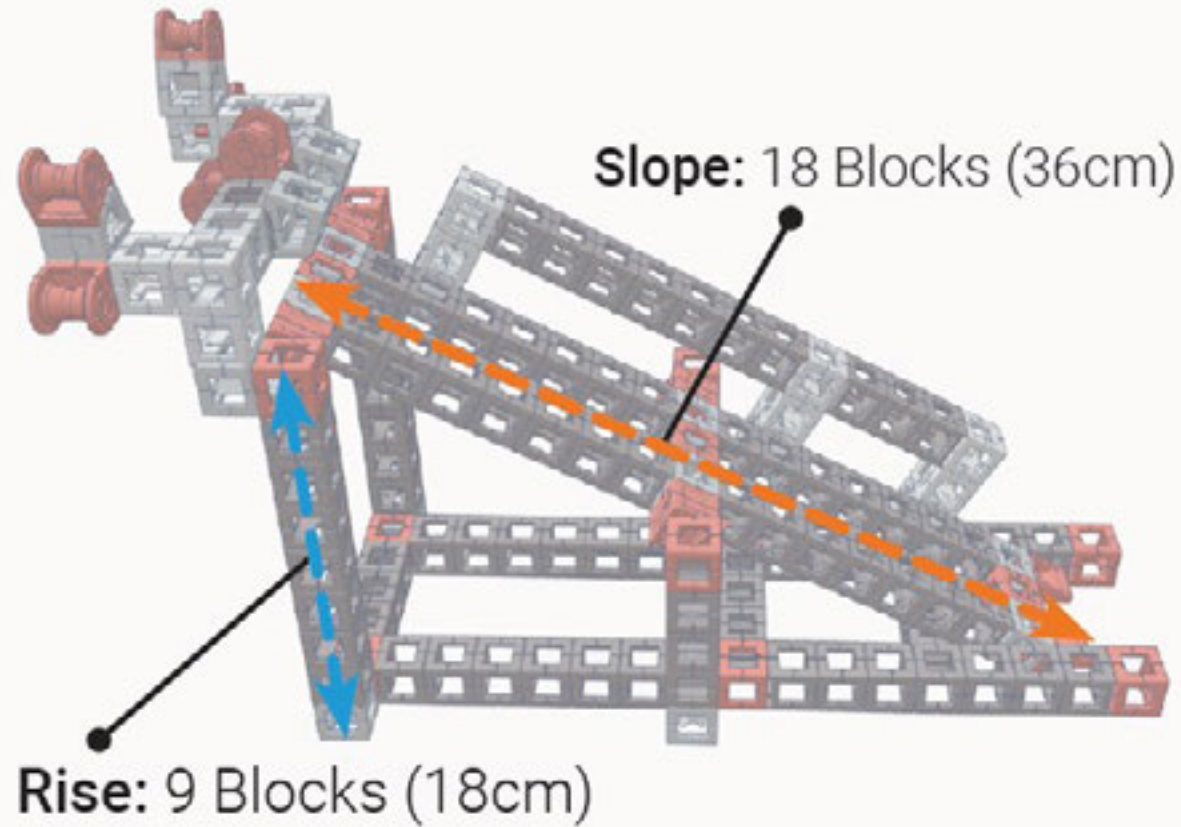

Fixed Pulley System

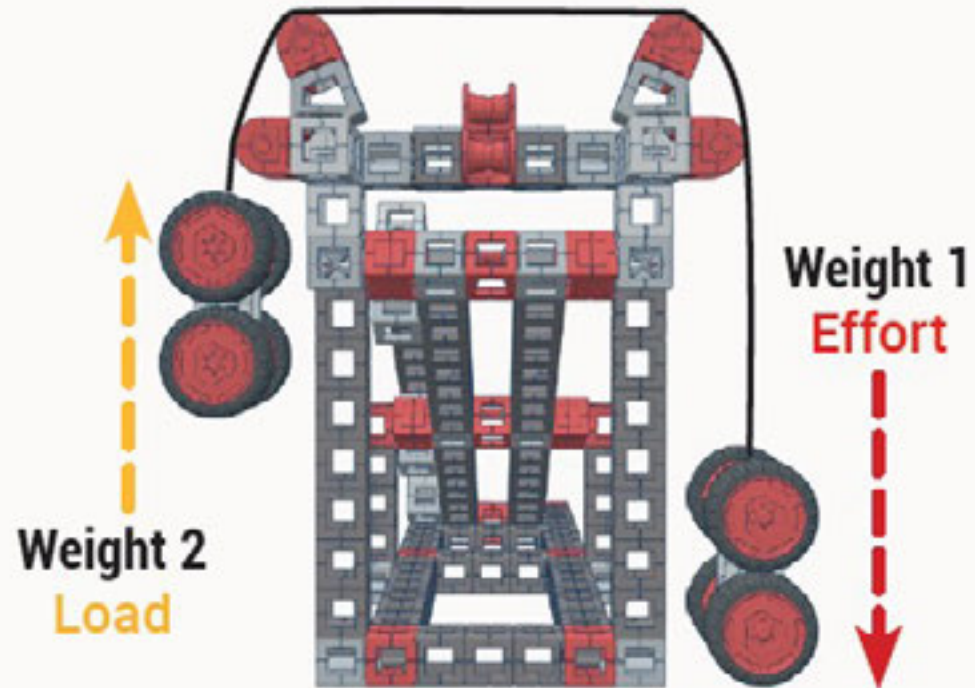

Inclined Plane

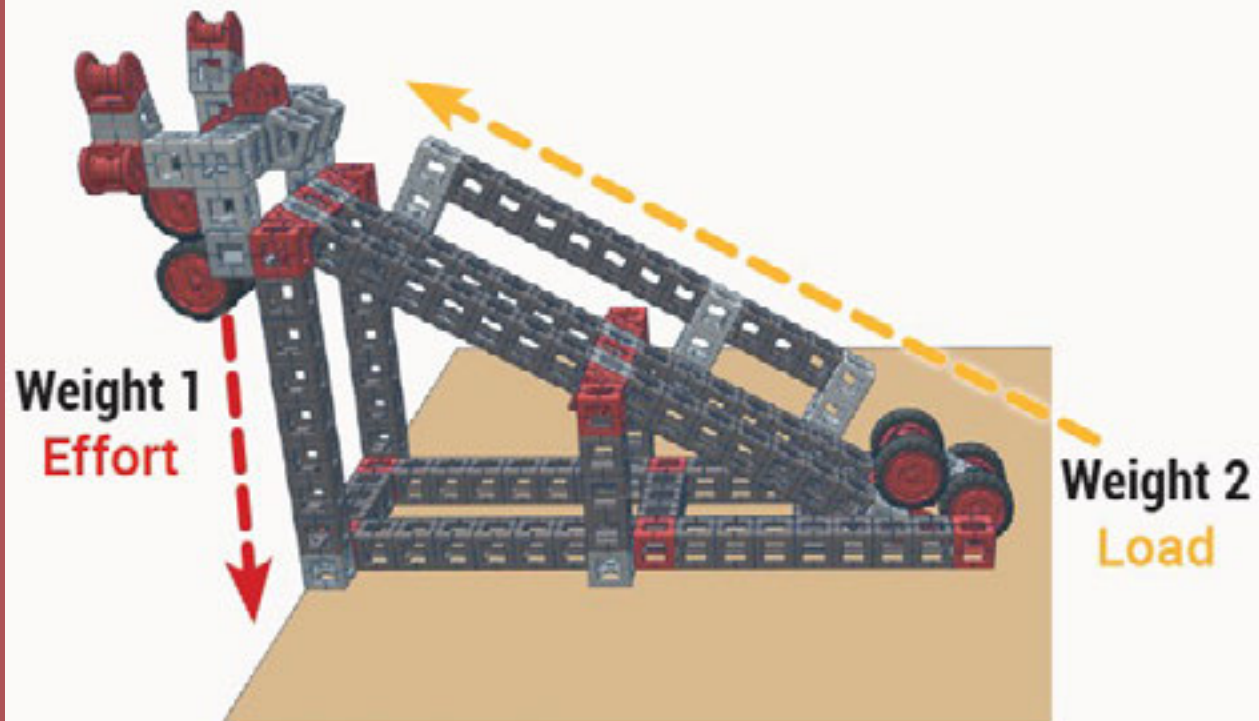

Calculating Mechanical Advantage

The inclined plane reduces effort by creating mechanical advantage. This is done by raising or lowering an object a further distance on a slope or incline to reach the desired height, instead of directly lifting or lowering the object straight up or down. To determine how much mechanical advantage exists in an inclined plane, divide the length of the **slope** by the height of the **rise**.

Formula

$$\text{Mechanical Advantage} = \frac{\text{Slope}}{\text{Rise}}$$

Understanding Inclined Plane Model

This model demonstrates how an inclined plane reduces the amount of effort needed to raise a load. When the weights were placed on the fixed pulleys, there was no mechanical advantage, so the weights balanced each other equally. In order to raise one of the weights, extra effort or mass would be needed to overcome the mass of the load.

When the weights were placed on the inclined plane, the mechanical advantage of the inclined plane allowed the effort to raise the load to the top of the incline. In this model the **slope** of the incline is 18 blocks (36 cm), and the **rise** is 9 blocks (18 cm). Divide $36/18$ and this will give a mechanical advantage of 2:1. Since the **slope** of the incline is twice as long as the **rise**, half the effort is needed to raise the load. This inclined plane is able to output a greater force than the input force that was applied to it.



Modify: Inclined Plane

Now that you have built an inclined plane that has a mechanical advantage of 2:1 (**slope** is twice the distance of the **rise**), modify the model to increase the mechanical advantage to 3:1.

Extension Activity

Design Brief: Scenario

An elderly neighbor fell and broke her hip. She now has to use a wheelchair to get around. There are a few stairs in front of her house that make it difficult to get in and out of the house.

Design & Engineering Challenge

Design and engineer a wheelchair ramp that will allow the elderly neighbor to easily get in and out of her house.

***Instructions to build the wheelchair assembly are pictured to the right.**

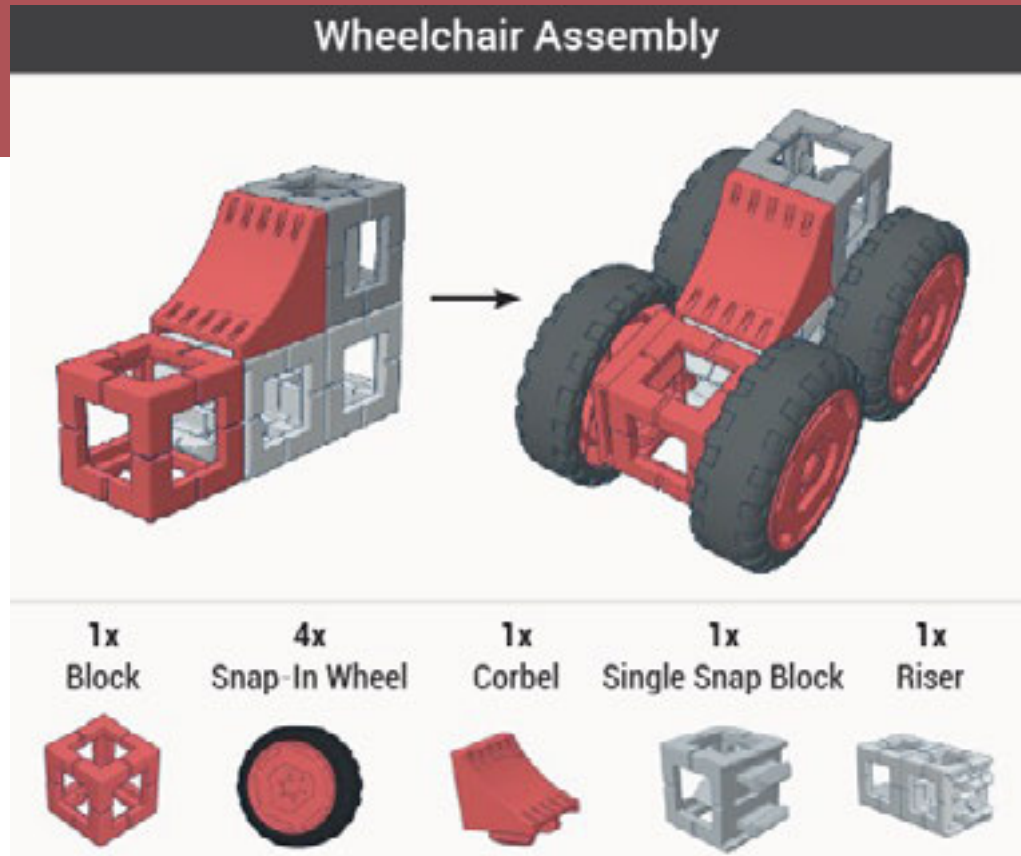

Specifications

Students will work in teams to complete this challenge

Teams must work through each step of the design & engineering process to design, prototype, and refine a custom inclined plane.

With each building component costing \$2, the ramp system must cost less than \$120.

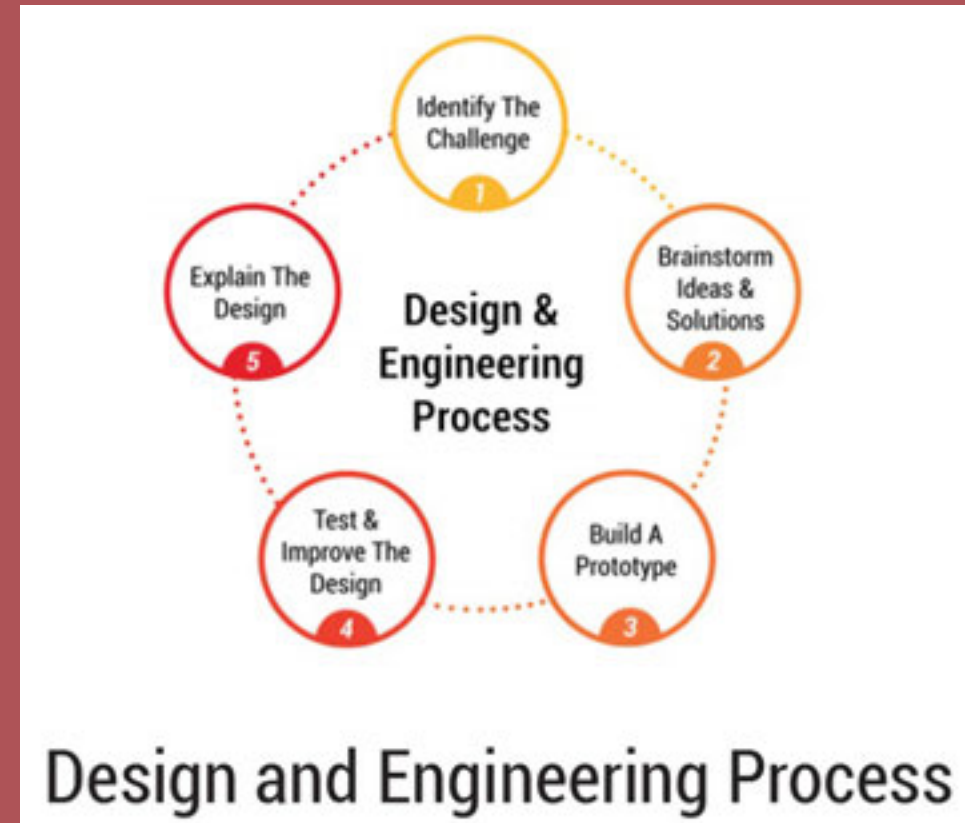

Clean Up

**BOTTOM OF
MODULE**

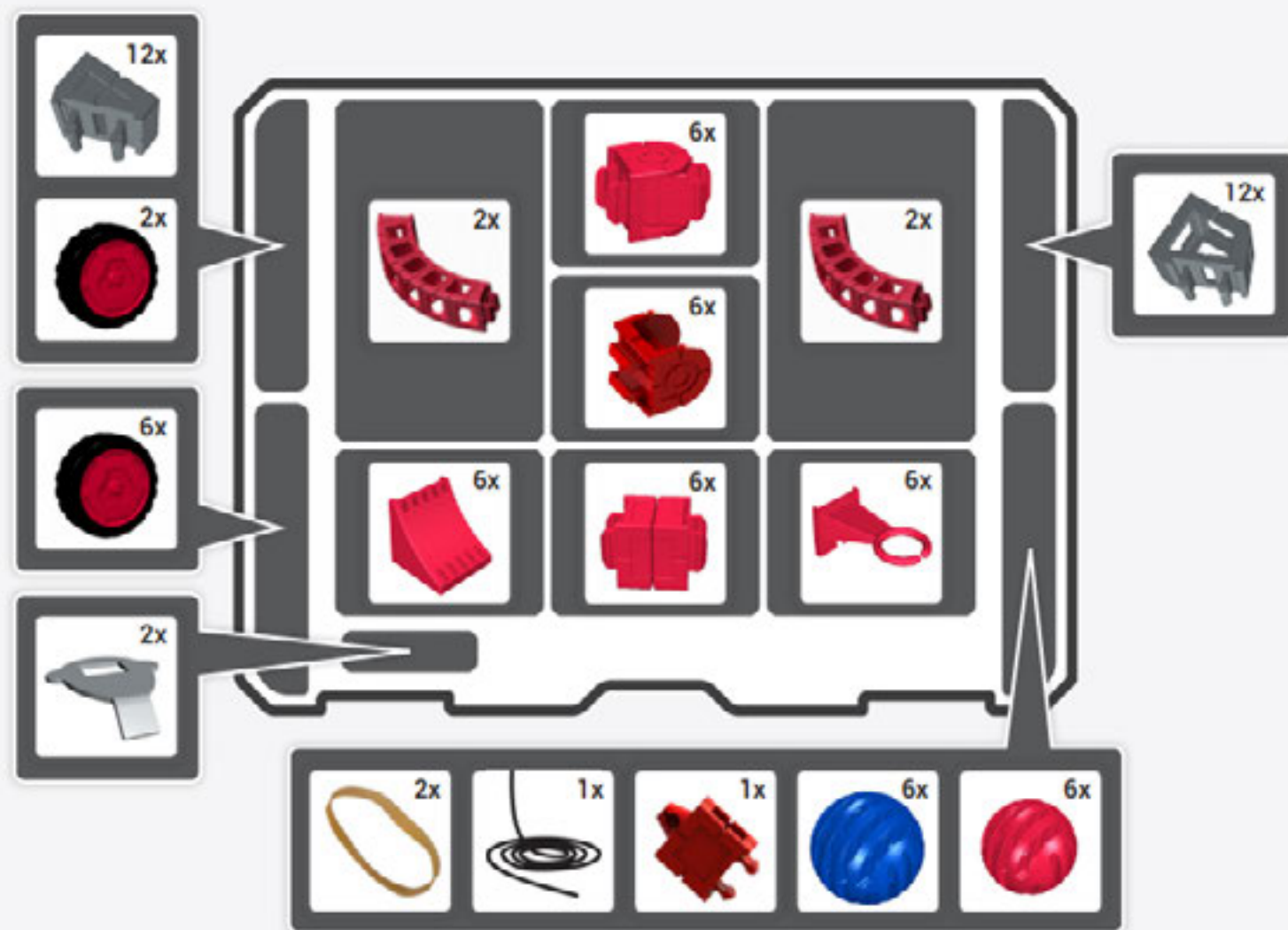

REMOVABLE
BINS

